



Kit Contents			
	Description	Part nr	Pcs
1.1	Shock absorber left	BMS 1101	1
1.2	Shock absorber right	BMS 2101	1
2	Dust boot	10216-01	2
3	Plastic spring spacer	25602-01	2
4	Spring		2
5	Rubber spring spacer	25601-01	2
6	Upper spring seat	24637-02	2
7	M14 nut	24627-04	2
8	Spacer (ID 10.5, T2)		2
9	C-spanner	24639-01	1
10	C-spanner	24639-03	1
11	Öhlins sticker	10207-01	1
	Öhlins Owner's Manual	07451-01	1

👁 Note!

Please note that this image is a general representation of the product and may differ slightly from your product.

👁 Note!

Please note that during storage and transportation, especially at high ambient temperature, some of the oil and grease used for assembling may leak and stain the packaging. This is in no way detrimental to the product, wipe off the excessive oil/grease with a cloth.

👁 Note!

Before installing this product, check the contents of the kit. If anything is missing, please contact an Öhlins dealer.

⚠ Warning!

Before installing this product, read the Öhlins Owner's Manual. The shock absorber is an important part of the vehicle and the vehicle stability.

Shock absorber Kit for BMW 1-series (E81, E82, E87, E88) & 3-series (E90, E91, E92, E93) – Front

BMS M101

Mounting Instructions



MOUNTING INSTRUCTIONS

⚠ Warning!

We strongly recommend to have an Öhlins dealer install this product.

⚠ Warning!

If working on a raised vehicle, ensure that it is securely supported to prevent it from tipping over.

👁 Note!

When working on this product, see the Vehicle Service Manual for vehicle specific procedures and important data.

1

Raise the vehicle and put it on jack stands.

⚠ Warning!

Ensure that it is securely supported.

2

Remove the front wheels.

3

Remove the stabilizer links and brake hose brackets from the standard struts. Loosen the bolts for the lower strut attachments.

👉 Caution!

Support the wheel hubs in an appropriate way on each side of the vehicle so that the brake hoses can not be damaged.

4

Loosen the upper attachments. Remove the original struts from the car.

5

Fit the dust boot (2), the plastic spring spacer (3), the spring (4), the rubber spring spacer (5) and the upper spring seat (6) to the strut according to fig 1.

Fit the OEM lower bearing spacer, the OEM top mount and the M14 top nut (7). Tighten the top nut to 35-40 Nm.

Set the spring preload, according to fig 5, and tighten the lower spring seat and the lock ring with the C-spanners.

👁 Note!

When tightening the top mount nut, the shock absorber shaft must be held in position with an Allen key.

6

Install the Öhlins McPherson struts on the vehicle according to fig 2.

Fig. 1

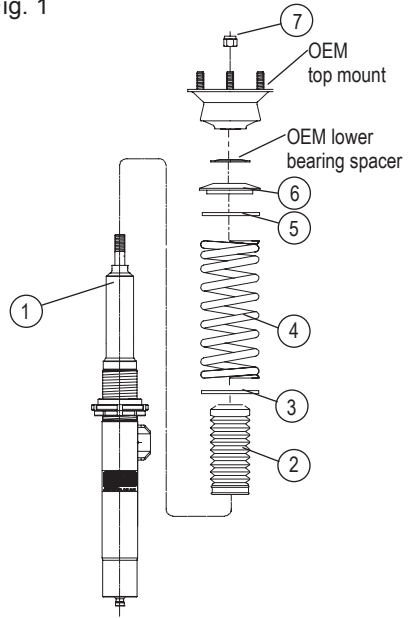

Fig. 2 **👉 Caution!**

Match the projection for positioning the shock absorber to the opening of the hub and assemble it.

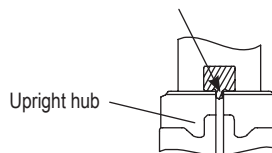
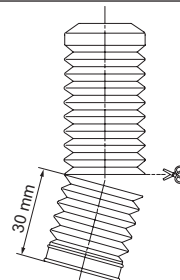

Fig. 3



MOUNTING INSTRUCTIONS

7

Mount the standard stabilizer links and OEM brake hose brackets to the Öhlins struts according to fig 4. Tighten the nut to OE specs.

8

Fasten the upper attachments.

9

Raise the wheel hub with a jack to remove the freeplay of the lower strut attachment bolts before tightening them.

Note!

Make sure that all bolts are tightened to the correct torque and that nothing fouls or restricts movement of the strut when it is being fully compressed or extended. Test this over the whole steering range from lock to lock.

10

Make sure that all removed parts are reinstalled in the same way as they were before the installation of the Öhlins shock absorber.

Fig. 4

Caution!

Assemble this spacer. The brake hose bracket is not correctly fixed without it.

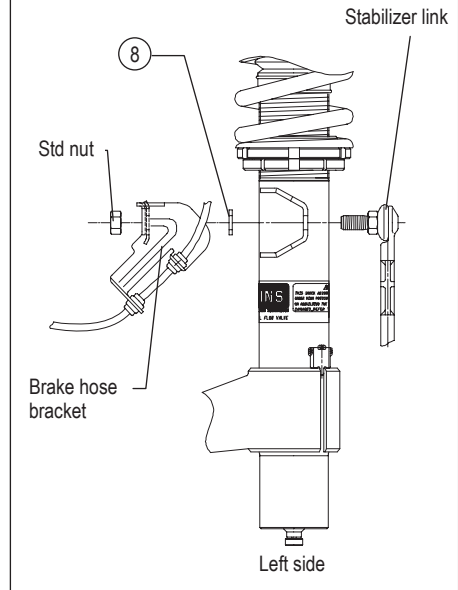

ADJUSTMENTS

⚠ Warning!

Before riding, always make sure that the basic settings made by Öhlins are according to recommended Set-up Data. Read about adjustments and setting up in the Öhlins Owner's Manual before you make any adjustments. Contact an Öhlins dealer if you have any questions about setting up.

The standard preload is 2 mm from a free length of 180 mm, giving 178 mm installed length, see fig 5.

SETUP DATA

Recommended set-up		
Setting adjustment		
Track	2-7	clicks
Winding road	5-10	clicks
Street	10-20	clicks
Spring preload	0-15	mm

Recommended spring

48000-19 (70N/mm)

The actual vehicle height

With the preload in its recommended position, the vehicle is lowered approximately 10 mm when compared to the original suspension. The adjustment range is approximately +5 mm to -20 mm ride height depending on car model, accessories and condition of OE suspension.

Fig. 5

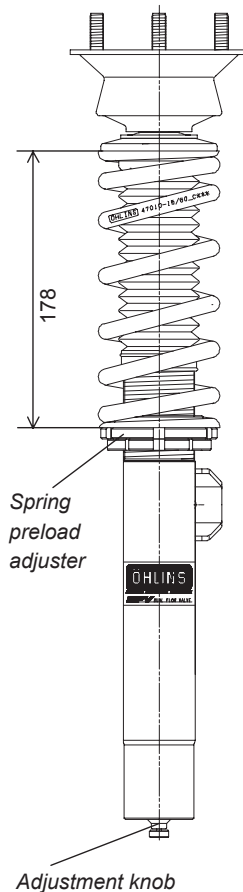

⚠ Warning!

The adjustment range is 0-15mm spring preload. If the spring preload is moved outside the adjustment range, the spring might come loose or coil bind.

Öhlins products are subject to continuous improvement and development, therefore, although these instructions include the most up-to-date information available at the time of printing, minor updates may occur.

To find the latest information contact an Öhlins distributor. Please contact Öhlins if you have any questions regarding the contents in this document.

Part no. MI_BMSMI01_0_front
Issued 2019-11-07

© Öhlins Racing AB. All rights reserved. Any reprinting or unauthorized use without the written permission of Öhlins Racing AB is prohibited.

Öhlins Racing AB
Box 722
S-194 27 Upplands Väsby, Sweden
Phone +46 8 590 025 00
fax +46 8 590 025 80



www.ohlins.com



Kit Contents			
	Description	Part nr	Pcs
1	Shock absorber	BMS 6I01	2
2	Dust boot	10216-01	2
3	Lock nut M10	24627-01	2
4	Adjuster	24631-03	2
5	Control wire 136mm	24632-03	2
6	Adjustment knob	24633-01	2
7	Screw M4	24633-02	2
8	Allen key	24639-02	1
9	Rubber seat (t=5mm)	25601-05	2
10	Plastic spring seat	25618-04	2
11	Spring		2
12	Rubber spring spacer	25601-03	2
13	Lock ring	24636-03	2
14	Spring seat	24635-03	2
15	Spring height adjuster	24651-02	2
16	Rubber seat (t=2mm)	25601-04	2

Note!

Please note that this image is a general representation of the product and may differ slightly from your product.

Note!

Please note that during storage and transportation, especially at high ambient temperature, some of the oil and grease used for assembling may leak and stain the packaging. This is in no way detrimental to the product, wipe off the excessive oil/grease with a cloth.

Note!

Before installing this product, check the contents of the kit. If anything is missing, please contact an Öhlins dealer.

Warning!

Before installing this product, read the Öhlins Owner's Manual. The shock absorber/front fork/steering damper is an important part of the vehicle and the vehicle stability.

Shock absorber Kit for BMW 1-series (E81, E82, E87, E88) & 3-series (E90, E91, E92, E93) – Rear

BMS M101

Mounting Instructions



MOUNTING INSTRUCTIONS

⚠ Warning!

We strongly recommend to have an Öhlins dealer install this product.

⚠ Warning!

If working on a raised vehicle, ensure that it is securely supported to prevent it from tipping over.

👁 Note!

When working on this product, see the Vehicle Service Manual for vehicle specific procedures and important data.

1

Raise the vehicle and put it on jack stands.

⚠ Warning!

Ensure that it is securely supported.

2

Remove the rear wheels.

3

Remove the lower and the upper attachments and remove the original shock absorbers.

4

Remove the spring.

5

Set the spring seat of the spring height adjuster to the position according to fig 6.

6

Remove the OEM upper spring cup according to fig 2.

7

Install the Öhlins spring assembly according to fig 4.

8

Fit the dust boot (2), the OEM washer, the OEM rubber bush and the OEM rubber cover according to fig 1. The upper OEM nut must be removed from the OEM rubber bush according to fig 3. Fit the OEM rubber bush without the OEM nut and tighten the lock nut (3) to 20 Nm.

👁 Note!

When tightening the lower mount nut, the shock absorber shaft must be held in position with a 5 mm spanner.

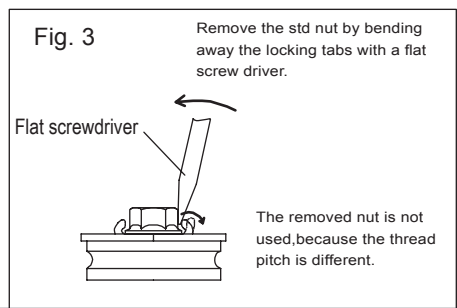
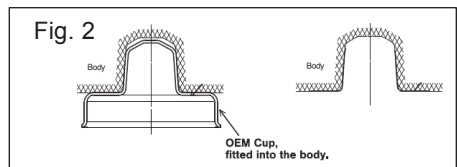
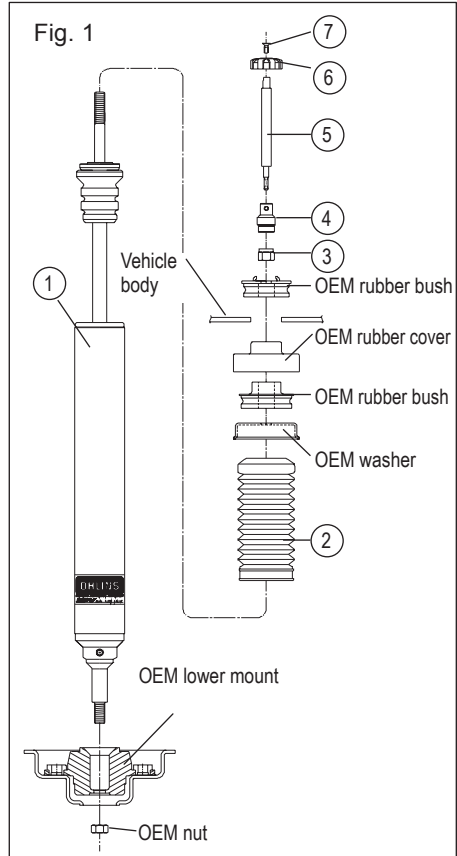

MOUNTING INSTRUCTIONS

9

Install the Öhlins shock absorbers on the vehicle.

10

Fasten the upper attachments.

👁 Note!

Make sure that all bolts are tightened to the correct torque and that nothing fouls or restricts movement of the shock absorber when it is being fully compressed or extended.

11

Make sure that all removed parts are reinstalled in the same way as they were before the installation of the Öhlins shock absorber.

12

Make a hole in each side panel as shown in fig 5.

Insert the top end of the wire (5) into the adjuster (4) and fasten it with the supplied Allen key. Insert the wire through the $\varnothing 10$ hole which is made in the side panel, and run it inside the panel. Fasten the adjustment knob (6) by tightening the M4 screw (7).

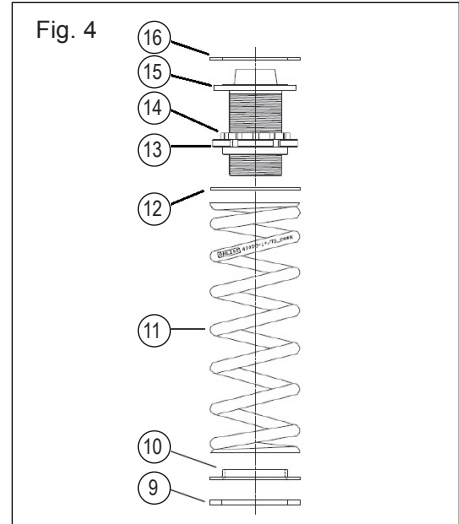
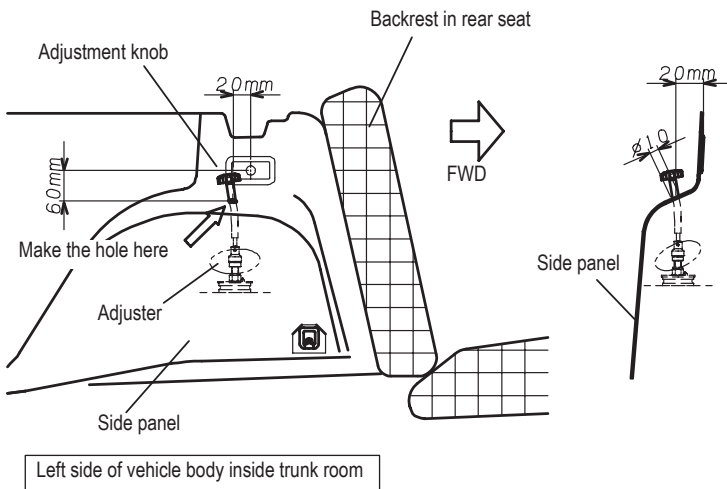

Fig. 5

Make a $\varnothing 10$ hole in the side panel in the shown position and pass the control wire through it.



ADJUSTMENTS

⚠ Warning!

Before riding, always make sure that the basic settings made by Öhlins are according to recommended Set-up Data. Read about adjustments and setting up in the Öhlins Owner's Manual before you make any adjustments. Contact an Öhlins dealer if you have any questions about setting up.

SETUP DATA

Recommended set-up		
Setting adjustment		
Track	2-7	clicks
Winding road	5-10	clicks
Street	10-20	clicks
Height adjuster 1-series:	45	mm
Height adjuster 3-series:	50	mm

Recommended spring

48010-39 (120N/mm)

The actual vehicle height

With the height adjuster in its recommended position, the vehicle is lowered approximately 10 mm when compared to the original suspension. The adjustment range is approximately +5 mm to -20 mm ride height depending on car model, accessories and condition of OE suspension.

⚠ Warning!

The height adjustment range is 45-55mm. If the height adjuster is moved outside the adjustment range, the spring might come loose or coil bind.

Fig. 6

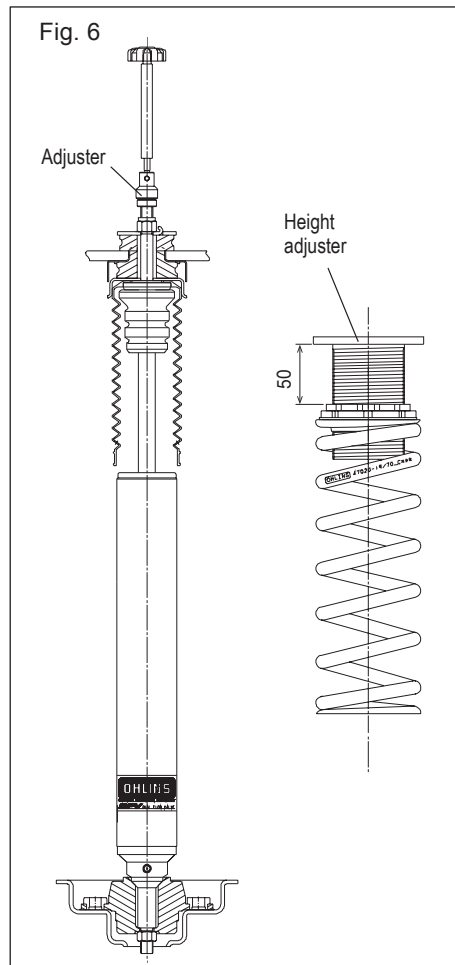

Öhlins products are subject to continuous improvement and development, therefore, although these instructions include the most up-to-date information available at the time of printing, minor updates may occur.

To find the latest information contact an Öhlins distributor. Please contact Öhlins if you have any questions regarding the contents in this document.

Part no. MI_BMSMI01_0_rear
Issued 2019-11-07

© Öhlins Racing AB. All rights reserved. Any reprinting or unauthorized use without the written permission of Öhlins Racing AB is prohibited.

Öhlins Racing AB
Box 722
S-194 27 Upplands Väsby, Sweden
Phone +46 8 590 025 00
fax +46 8 590 025 80



www.ohlins.com